

SABER DUAL PRIMARY® CLEANER

- ✓ Simple Installation
- ✓ Low Maintenance
- ✓ Splice Safe
- ✓ Fast Delivery
- ✓ Heavy-Duty

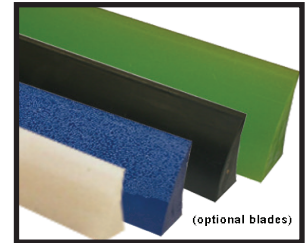

Two curved, extremely tough polyurethane blades leave no doubt that belts are carry-back-free.

A narrower front cleaner that eliminates bulk of carryback off the center of the belt, backed by a second, wider cleaner to remove material out to the edges of the belt.

Each cleaner is equipped with Arch's patented Twister Tensioner that maintains optimum blade-to-belt pressure.

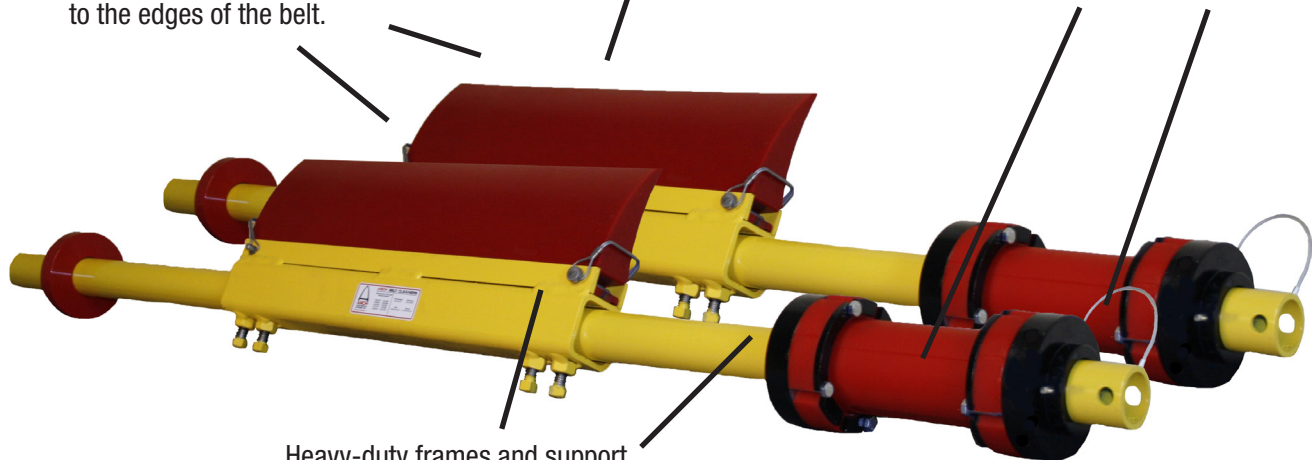

Heavy-duty frames and support tubes confront tough conditions with even tougher performance.



- Patented *Twister Tensioner*® maintains consistent blade-to-belt pressure and its core is **GUARANTEED FOR LIFE!**
- Two Saber primary cleaners mounted at the head pulley for maximum defense against carryback.
- Decreases cleanup costs by eliminating carryback **BEFORE** it reaches the ground.
- Compact design easily installed in tight spaces.
- Non-segmented blade is quickly replaced with single-pin removal.
- Multiple blade options include high-temperature, high moisture, high-speed, and food-grade.



WHO IS ARCH ENVIRONMENTAL?

Manufacturer and worldwide distributor of preferred bulk conveyor components since 1975.



800.553.4567 www.archenv.com

MECHANICAL DIVISION

Belt Cleaners • Belt Alignment • Sealing Systems
Dust Control Systems • Impact/Slider Systems

ELECTRICAL DIVISION

Belt Scales • Metal Detectors • Pull Cord Switches
Belt Protection Devices • Conveyor Control Systems

SABER DUAL PRIMARY® CLEANER

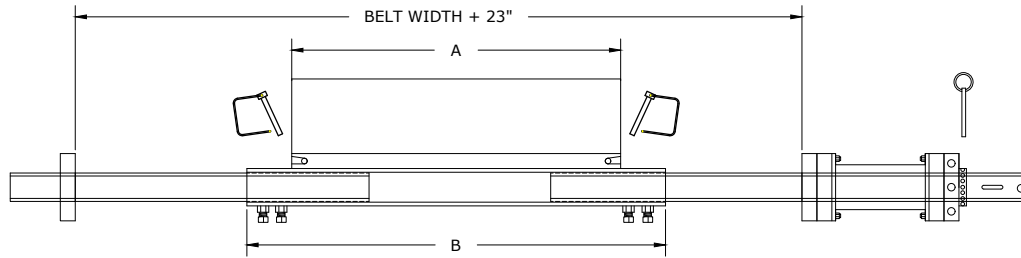

MCN**000_0000_0TA00100000000
 A B
 1st PRIMARY CLEANER

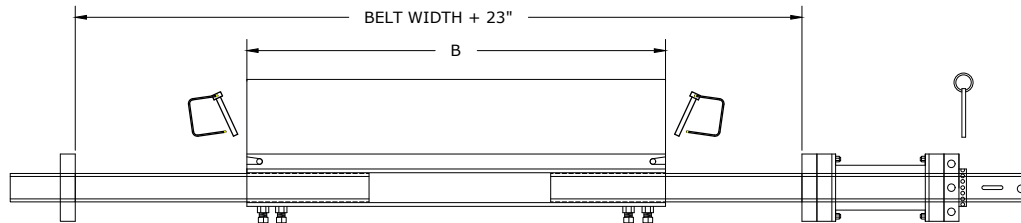

MCN**000_0000_0TA00100000000
 B B
 2nd PRIMARY CLEANER

NOTE: IF LONGER SPAN IS REQUIRED, A LONGER MAINFRAME WILL BE REQUIRED. (CONSULT FACTORY FOR DETAILS)

BELT CLEANER SELECTION GUIDE

PULLEY DIAMETER					
24"+ [609mm +]					
16" - 36" [406mm - 914mm]					
4" - 16" [101mm - 406mm]					
	48" MAX				
	MINI	SB	SCM	MX	XS
BELT SPEED					
0-450 FPM [0-2.3m/s]					
450 FPM + [2.3m/s +]					

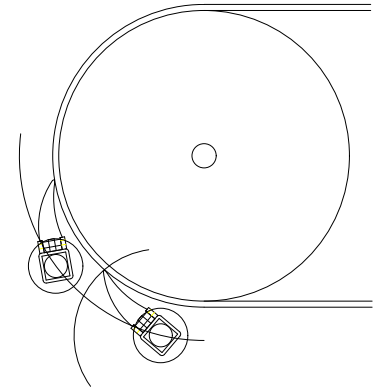

Standard Blades (RED)
 Temp Range: 180-220 F

High-Moisture Blades (GRAY)
 Temp Range: 180-220 F
 15%+ Moisture Content

Cermic Blades (BLUE)
 High Friction/High Speed
 750+ ft/min.

High Temperature Blades (GREEN)
 Temp Range: Up to 300 F

Non-Pigment Blade (WHITE)
 Same as Standard Red Blades
 Ideal for color sensitive materials

Food Grade (NATURAL)
 FDA approved for mild contact
 with food products.

Covered under one or more of the following patents:
 4,202,437;4,231,471;4,436,446;4,489,823;4,533,036;4,779,716;4,877,125;
 4,989,727;5,149,305;5,222,588;5,222,589;5,219,063;5,350,053;5,725,083
 other patents pending



Note: If available, prices vary with options.