

# 684 2-DK

## INCLINED SCREEN



The Finlay® 684 inclined screen is a compact easily transportable machine that offers operators rapid set up and tear down times.

The screenbox features two large 4.3m x 1.7m (14' x 5' 7") inclined screen decks giving a large screening area to provide efficient screening and high capacity.

The screenbox features quick wedge tensioning on the top deck, access holes and bottom deck hydraulic tensioning system to reduce time required for mesh changes.

### FEATURES:

- > Double deck 4.3m x 1.7m (14' x 5' 7") screen with full catwalk access.
- > Maximum utilisation of the two 4.3m x 1.7m (14' x 5' 7") decks provides ultra-efficient screening capabilities even at small aggregate sizes.
- > A combination of quick wedge tensioning on the top deck, convenient access holes and hydraulic tensioning on the bottom deck ensure mesh set up and change out times are kept to an absolute minimum.

### TRANSPORT DIMENSIONS

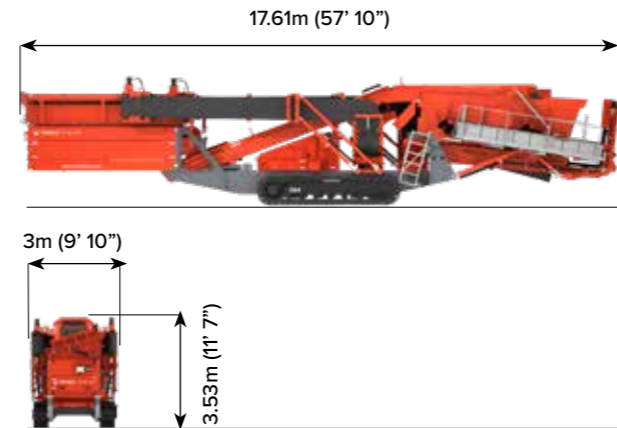

### WORKING DIMENSION

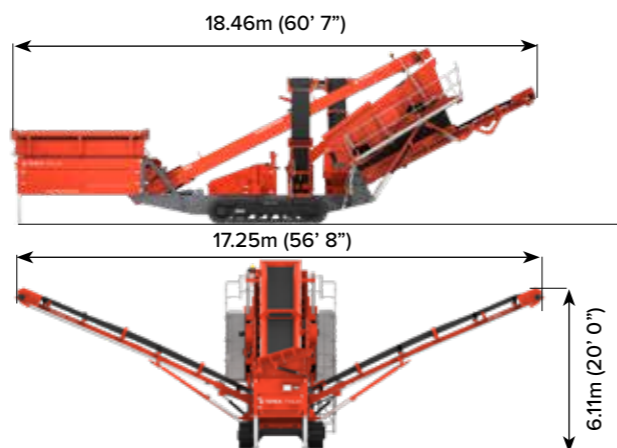

**MACHINE WEIGHT:** 28,750kg (63,380lbs) (With tipping grid)

### 1 HOPPER/FEEDER

Hopper Capacity: 8m<sup>3</sup> (10.5yd<sup>3</sup>)  
Feed height: 3.45m (11' 4")  
Feed in width: 4.77m (15' 8") (grid wing plates)

### 2 OVERSIZE PLUS CONVEYOR

Belt width: 650mm (26")  
Belt spec: Chevron 2 ply EP250  
Hydraulic Folding  
Discharge Height: 4.76m (15' 7")  
Stockpile capacity: 194m<sup>3</sup> (254yd<sup>3</sup>)

### 3 MAIN CONVEYOR

Belt width: 1m (40")  
Steel skirted full length of conveyor  
3 number Anti-rollback Plates  
Conveyor can be raised while



### T-LINK TELEMATICS

T-Link telematics hardware and software along with free seven year data subscription are fitted and installed as standard.

### 4 SCREENBOX

Both decks: 4.3m x 1.7m (14' x 5' 7")  
Screen Angle: 18° - 37°, hydraulic adjust  
Abrasion resistant material impact plate  
Galvanised access catwalk at both sides and top end of screen  
Total screening area: 14.6m<sup>2</sup> (156ft<sup>2</sup>)

### 5 MIDDLE GRADE CONVEYOR

Belt width: 650mm (26")  
Belt spec: Chevron 2 ply EP250  
Hydraulic Folding  
Discharge Height: 4.76m (15' 7")  
Stockpile capacity: 194m<sup>3</sup> (254yd<sup>3</sup>)

### 6 FINES CONVEYOR

Belt width: 1.2m (48")  
Working Angle: Variable 25° (Max)  
Standard Discharge Height: 4.15m (13' 7")  
Stockpile capacity: 106.3m<sup>3</sup> (139yd<sup>3</sup>) @ 25°

