

# 694+

## INCLINED SCREEN



The Finlay® 694+ Portable Inclined Screen has been developed to fulfil the demands of high production producers.

The new high energy screenbox features three full size 6.1m x 1.53m (20' x 5') decks that can process fine, sticky and dirty material with ease in quarrying, mining, sand and gravel, coal, woodchip and topsoil applications.

The large hopper / feeder is fitted with variable speed belt feeder to ensure consistent flow of material and can be fitted with remote tipping grid or double deck vibrating grid.

The hydraulics system has been upgraded to provide the optimum balance of power and efficiency and the powerpack designed to operate at lower engine speeds to raise cost-efficiency in the long term without compromising on performance.

The model is available with hybrid technology consisting of on-board electrical motors permitting the flexibility to run the plant from an outside power supply or standard on-board engine.

### FEATURES:

- Simplified and reconfigured folding mechanism for the onboard product conveyors for ease of deployment and user-friendly operation.
- Hydraulic folding catwalks as standard for improved onsite efficiency and to enable rapid screenbox deployment.
- Maximum utilisation of three 20' x 5' (6.1m x 1.53m) decks provide ultra-efficient screening capacities even at small aggregate sizes.
- The fourth (oversize plus) conveyor provides variable tilt and side slew capability to accurately discharge materials for re-circulation to crushers or for stockpiling.
- Screen box angle can be hydraulically adjusted to an angle between 18° and 32°.

### TRANSPORT DIMENSIONS

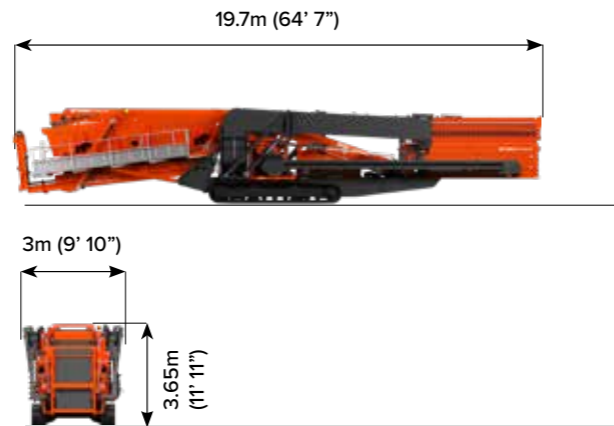

### WORKING DIMENSION

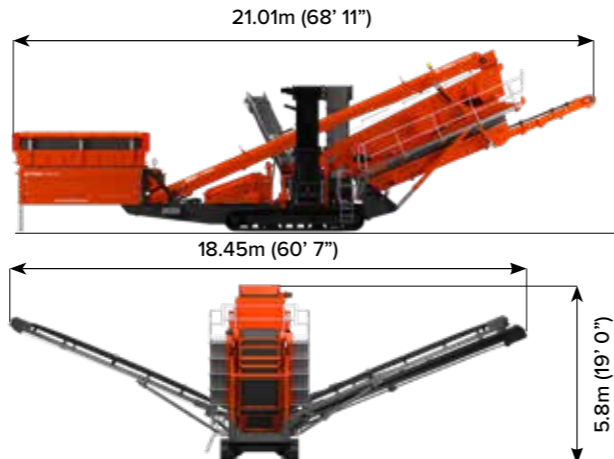

**MACHINE WEIGHT:** \* 39,250kg (86,550lbs)\*  
(With tipping grid)

### 1 HOPPER/FEEDER

Hopper Capacity: 8m<sup>3</sup> (10.5yd<sup>3</sup>)  
Feed height: 2.5m (8' 2") - no grid  
Feed in width: 4.2m (13' 9")  
Beltfeeder belt width: 1.2m (48")

### 2 MAIN CONVEYOR

Belt width: 1.2m (48")  
Hydraulic discharge height adjustment  
Belt Speed: 92 mpm (3 02' per min)  
Steel skirted full length of conveyor

### 3 OVERSIZE PLUS CONVEYOR

Belt width: 500mm (20")  
Working Angle: Variable 24°  
Discharge Height: Variable 5.4m (Max)  
Operating angle variable between 0° and 80°  
Stockpile capacity: 152m<sup>3</sup> (198yd<sup>3</sup>) @ 40°

### 4 OVERSIZE CONVEYOR

Belt width: 800mm (32")  
Working Angle: 22°  
Hydraulic Folding  
Discharge Height: 5.1m (16' 9")

### 5 SCREENBOX

All decks: 6.1m x 1.53m (20' x 5')  
Hydraulic Folding Catwalks  
Screen Angle: 18° - 32°, hydraulic adjust  
Total screening area: 28m<sup>2</sup> (301ft<sup>2</sup>)

### 6 FINES CONVEYOR

Belt width: 1.2m (4 8")  
Working Angle: Variable 27.5° (Max)  
Standard Discharge Height: 5.5m (18' 1")  
Stockpile capacity: 159m<sup>3</sup> (208yd<sup>3</sup>)



### T-LINK TELEMATICS

T-Link telematics hardware and software along with free seven year data subscription are fitted and installed as standard.

